



Cordless Stick Vacuum Cleaner

User Manual



VRT 86325 VI

EN



01M-8915473200-0824-01

Please read this guide first!

Dear Customer,

Thank you for choosing a Beko product. We would like you to achieve the optimal efficiency from this high quality product which has been manufactured with state of art technology. Please make sure you read and understand this guide and supplementary documentation fully before use and keep it as a reference. Include this guide with the unit if you hand it over to someone else. Observe all warnings and information herein and follow the instructions.

Symbols and their meanings

These symbols are used throughout this guide:



Important information and useful hints about usage.



WARNING: Warnings against dangerous situations concerning the security of life and property.



Electric shock protection rating



RECYCLED &
RECYCLABLE PAPER

CONTENTS

1 Important safety and environmental instructions 4-8

1.1 General safety	4
1.2 Compliance with the WEEE Directive and disposal of the waste product	7
1.3 Packaging information	7
1.4 Information on Waste Batteries .	7
1.5 What to do for energy saving . . .	7
1.6 Compliance with RoHS Directive	7
1.7 Plug Wiring	8

2 Overview 9-10

2.1 Controls and components	10
2.2 Technical data	10

3 Installation 12

3.1 Intended use	12
3.2 Installation of the charging dock	12
3.3 Installation of the body and the brush	12

4 Operation 13-17

4.1 Charging the appliance	13
4.2 Usage	14
4.3 Accessories	15
4.4 LED screen indicators	17

5 Cleaning and maintenance 18-21

5.1 Cleaning the Dust container and Filters	18
5.2 Cleaning of the brush	20
5.3 Storage	21
5.4 Transport and shipping	21

1 Important safety and environmental instructions

This section contains safety instructions to prevent hazards that can result in injury or property damage.

Any warranty is void if these instructions are not followed.

1.1 General safety

- This appliance complies with international safety standards.
- This device can be used by children over 8 years of age, people with physical, sensory or mental challenges or people with lack of experience or knowledge; as long as control is ensured or information is provided regarding the hazards. Children must not play with the appliance. Cleaning and user maintenance shall not be carried out by unattended children.
- Do not use the appliance if the power cord or the appliance is damaged. Contact authorized service.
- Your mains power supply shall match the information shown on the rating plate label of the appliance.
- Do not use the appliance with an extension cord.
- To prevent damage to the power cord, prevent it from being pinched, crimped or rubbed against sharp edges.
- Do not touch the plug of the appliance with damp or wet hands while the appliance is plugged in.
- Do not pull on the cord while unplugging the appliance.
- Do not vacuum flammable materials and ensure that the cigarette ashes are cooled down before vacuuming them.
- Do not vacuum water and other fluids.
- Protect the appliance against precipitation, humidity and heat sources.

1 Important safety and environmental instructions

- Do not use the appliance in or near explosive or flammable environments and substances.
- Unplug the appliance before cleaning and maintenance.
- Do not immerse the appliance or its power cord in water for cleaning.
- Do not disassemble the appliance.
- Use only original parts or parts recommended by the manufacturer.
- To prevent blockage of the filter or damage to the motor, do not vacuum cement, plaster or fragments of compressed paper.
- Use the appliance with the adapter delivered with the appliance only.
- Do not use the appliance without filters, it may get damaged.
- If you keep the packaging materials, keep them out of the reach of children.
- This appliance is not intended to be used by persons, including children, with physical, sensory and mental disabilities or those who have not adequate experience and knowledge regarding its use, unless they are under the supervision of a person responsible for their safety or they are informed about the operation of the appliance.
- Children shall be supervised to prevent them from playing with the appliance.
- Unplug the adaptor and remove the battery pack before any cleaning or maintenance procedure.
- To avoid any risk of hazard, a damaged adaptor shall be replaced by the manufacturer, the authorized representative of the manufacturer or a similarly qualified technician.
- Keep your fingers, hair and loose clothes away from moving parts or clearances while vacuuming.

1 Important safety and environmental instructions

- Batteries shall be removed from the appliance before discarding the appliance.
- Disconnect the appliance from power supply before removing the battery.
- Please discard used batteries in accordance with local laws and regulations.
- The batteries included in this appliance may only be replaced with qualified persons.
- Appliance is not intended to be operated for commercial purposes. This appliance is not designed for commercial use, it is intended for home use and in applications as follows:
 - In the staff kitchens of the stores, offices and other working environments
 - In farm houses;
 - By customers in hotels, motels or other accommodation facilities
 - In hostels or similar environments.
- **WARNING:** Use the HCX1501-3200450E removable supply unit delivered with the appliance to charge to the battery.
- This appliance shall not be operated by children and people with limited physical, sensory and cognitive skills or people with lack of experience and knowledge unless they are under supervision or they are provided with the relevant instructions.
- Children shall be supervised to prevent them from playing with the appliance.

1 Important safety and environmental instructions

1.2 Compliance with the WEEE Directive and disposal of the waste product



This product complies with EU WEEE Directive (2012/19/EU). This product bears a classification symbol for waste electrical and electronic equipment (WEEE). This symbol indicates that this product shall not be disposed with other household wastes at the end of its service life. Used device must be returned to official collection point for recycling of electrical and electronic devices. To find these collection systems please contact to your local authorities or retailer where the product was purchased. Each household performs important role in recovering and recycling of old appliance. Appropriate disposal of used appliance helps prevent potential negative consequences for the environment and human health.

1.3 Packaging information



Packaging materials of the product are manufactured from recyclable materials in accordance with our National Environment Regulations. Do not dispose of the packaging materials together with the domestic or other wastes. Take them to the packaging material collection points designated by the local authorities.

1.4 Information on Waste Batteries



This symbol on rechargeable batteries/batteries or on the packaging indicates that the rechargeable battery/battery may not be disposed of with regular house hold rubbish. For certain rechargeable batteries/batteries, this symbol may be supplemented by a chemical symbol. Symbols for mercury (Hg) or lead (Pb) are provided if the rechargeable batteries/batteries contain more than 0,0005 % mercury or more than 0,004 % lead.

Rechargeable batteries/batteries, including those which do not contain heavy metal, may not be disposed of with household waste. Always dispose of used batteries in accordance with local environmental regulations. Make enquiries about the applicable disposal regulations where you live.

1.5 What to do for energy saving

- When using your appliance, adjust the speed settings according to the surface, in order to save energy.
- Normally, lower speeds are used when cleaning hard surfaces, curtains and sofas, while high speeds are used in for cleaning carpets.

1.6 Compliance with RoHS Directive

The product you have purchased complies with EU RoHS Directive (2011/65/EU). It does not contain harmful and prohibited materials specified in the Directive.

1 Important safety and environmental instructions

1.7 Plug Wiring

The moulded plug on this appliance incorporates a 13 A fuse. Should the fuse need to be replaced an ASTA approved BS1362 fuse of the same rating must be used. Do not forget to refit the fuse cover. In the event of losing the fuse cover, the plug must not be used until a replacement fuse cover has been fitted. Colour of the replacement fuse cover must be the same colour as that visible on the pin face of the plug. Fuse covers are available from any good electrical store.

Fiting a different plug

- As the colours of the wires in the mains lead of this appliance may not correspond with the coloured markings identifying the terminals on your plug, proceed as follows:
- Brown cable = L (Live)
- Blue cable = N (Neutral)
- Green/yellow cable must be connected to ground (E) \equiv line
- With the alternative plugs a 13 A fuse must be fitted either in the plug or adaptor or in the main fuse box. If in doubt contact a qualified electrician.

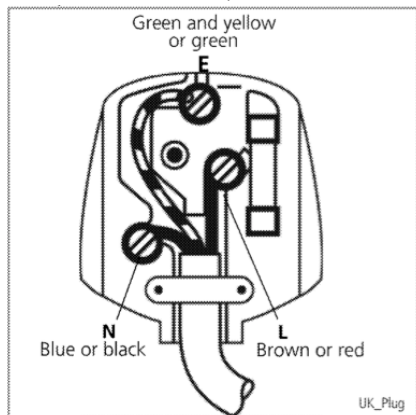

2 Overview

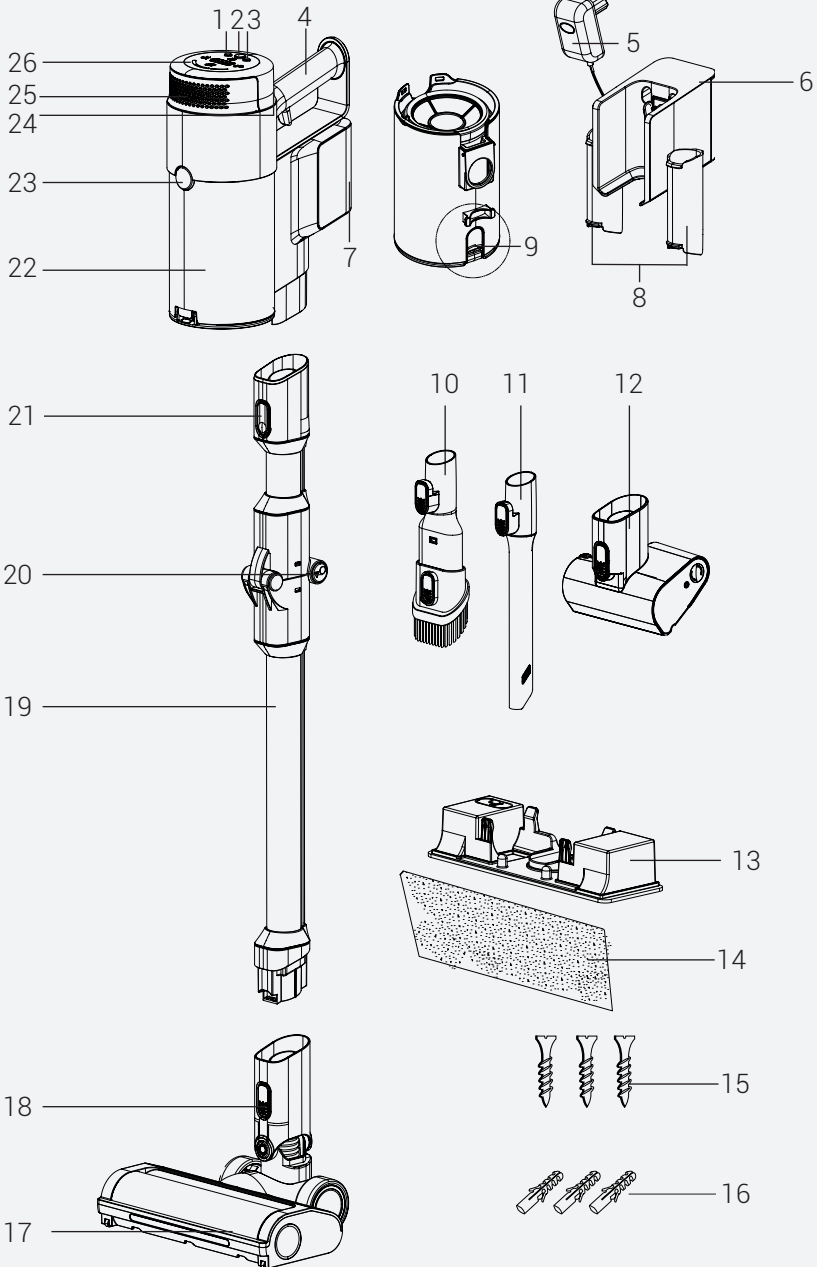

2 Overview

2.1 Controls and components

1. Speed level adjustment button
2. On/off button
3. Speed level adjustment button
4. Handle
5. Adaptor
6. Charging dock
7. Battery pack release button
8. Accessory attachment compartments
9. Dust container empty button
10. Combination tool
11. Crevice
12. Pet brush
13. Mop attachment; Water Tank
14. Mopping cloth (x2 pcs)
15. Screw (3 pcs)
16. Dowel (3 pcs)
17. Electrical turbo brush
18. Electrical turbo brush release button
19. Foldable tube
20. Tube fold button
21. Tube release button
22. Dust container
23. Dust container release button
24. Hepa filter cover release button
25. Hepa filter cover
26. LED screen

2.2 Technical data

	450 W
Input	100 - 240 V~ 50-60 Hz 0,5 A
Output	32 V  0.45 A
Charging time	4-6 hours
Runtime at max. power	10 mins
Runtime at mid power	30 mins
Runtime at min. power	60 mins

The rights to make technical and design changes are reserved.

The values provided with the appliance or its accompanying documents are laboratory readings in accordance with the respective standards. These values may differ depending on the use and ambient conditions.

2 Overview

External Power Supply Parameter

Manufacturer:	Guangdong Huachuangxing Power Supply Co.,Ltd
Model ID:	HGX1501-3200450E
Input Voltage:	100-240V~
Input Frequency:	50-60Hz
Input Current:	0.5A
Output Voltage	32.0V
Output Current	0.45A
Output Power:	14.4W
Average active efficiency:	85.5%
Efficiency at low load (10%):	83.33%
Power consumption under no load:	0.041W

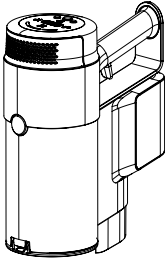
Usage Type	Speed Level	Usage Time	
Use with tube and brush	Minimum speed	Up to 40 min	
	Medium speed	Up to 25 min	
	Maximum speed	Up to 8 min	
Handheld (With non-motorized accessories)	Minimum speed	Up to 60 min	
	Medium speed	Up to 30 min	
	Maximum speed	Up to 10 min	

3 Installation

3.1 Intended use

This appliance is intended for household use and it is not suitable for industrial use.

3.2 Installation of the charging dock

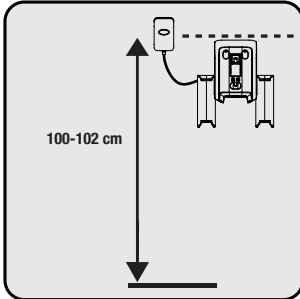

Position the charging dock at a height of minimum 100-102 cm from the ground.

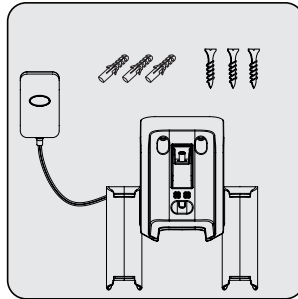

1- Fix three dowels on the wall
2- Place three screws into their locations on the charging dock and mount on the dowels on the wall.

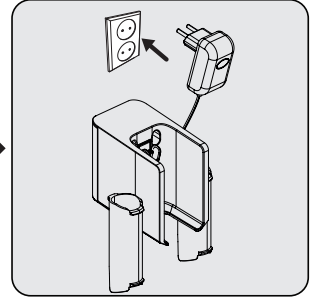

Plug the charging adaptor to the socket.

3.3 Installation of the body and the brush

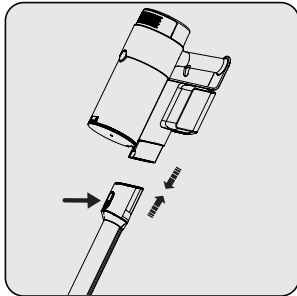

Push the tube in the direction of arrow towards the body by pushing on the tube release button.

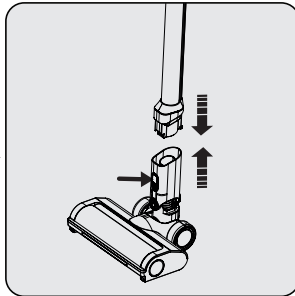

Press the electric turbo brush release button on the electric turbo brush and push it in the direction of arrow towards the tube.

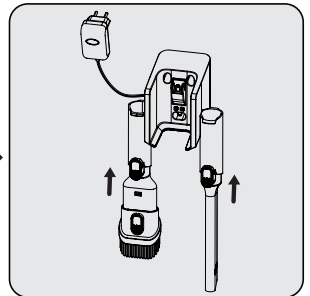

Attach crevice attachment and combination tool to the charging dock.

4 Operation

4.1 Charging the appliance



WARNING: If you want to use the device for the first time or after a long time, charge the batteries completely before using.

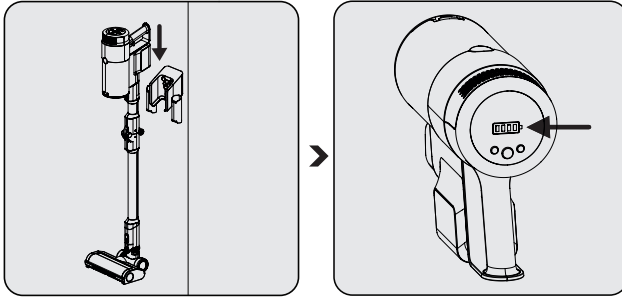

Place the appliance on the charging dock.

When you place appliance to the charging dock, it starts to charge and the battery charge levels shall be displayed on the screen. When all the battery levels are full and stable, the charging process will be completed.



It takes up to 4 to 6 hours to charge the appliance completely. The appliance shall not be operated while charging.



If the appliance is placed on the charging dock while it is being operated, it shall be stopped automatically.

4 Operation

4.2 Usage

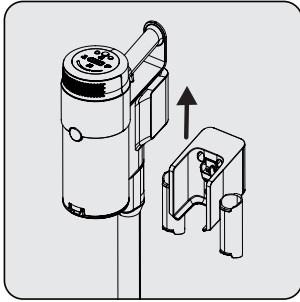

1- Pull the appliance from the charging dock upward.

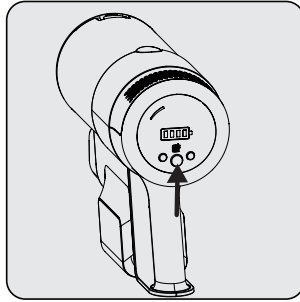

Press the on/off button to operate the appliance. The appliance starts operating with the minimum power when the on/off button is pressed.

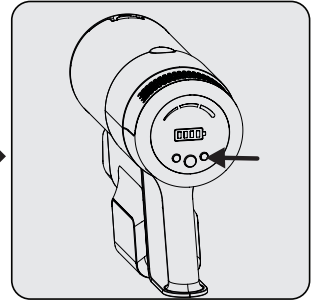

To adjust the speed level, push the button. On the screen, which suction mode is being used will be shown as min, mid and high. By pressing the - and + buttons, the speed level can be adjusted.



The appliance may be placed for charging before the complete discharging of the battery. The appliance may be kept continuously as charging on the charging dock until the next operation.

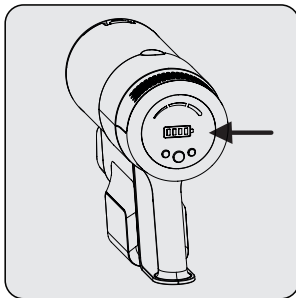

Pay attention to the battery levels during operation. Battery levels should be tracked during usage when it is empty, the appliance stops operating automatically.

4 Operation

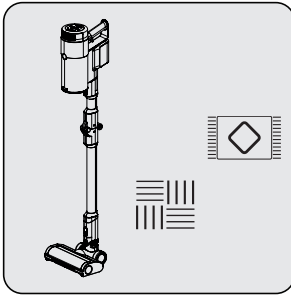

This appliance is suitable for use on carpets and hard floors.

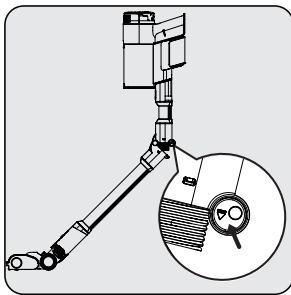

You can fold the tube for easy access to areas such as armchairs and under tables. You can fold the tube by pressing the round button mechanism on the left side that allows the tube to be folded.

4.3 Accessories

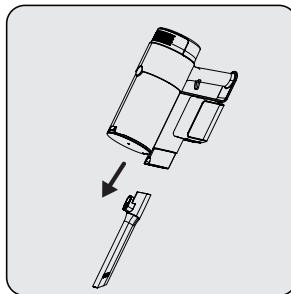

Crevice: Suitable for vacuuming the rear of the furnitures, hard to reach areas and narrow areas.

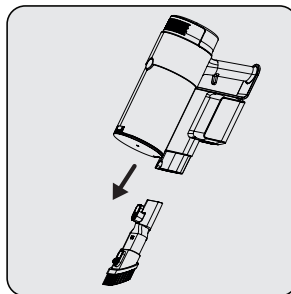

Combination tool: Suitable for vacuuming curtains, sofas, waxed furniture and delicate and fragile objects.

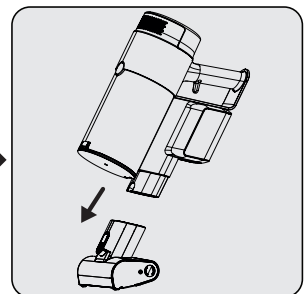

Mini turbo pet brush: Suitable for vacuuming floorings, stair steps, car interiors, sofas and seat, etc. It is also used for vacuuming pet hair on such surfaces.

4 Operation

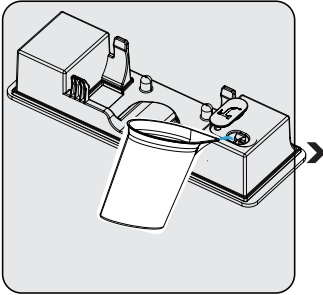

Mop Attachment: Suitable for mopping hard floors. Mop Apparatus, fill the water tank with clean water.

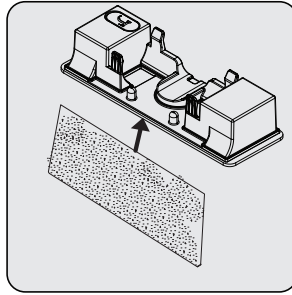

Velcro mop cloth; Secure the mop attachment to the bottom surface.

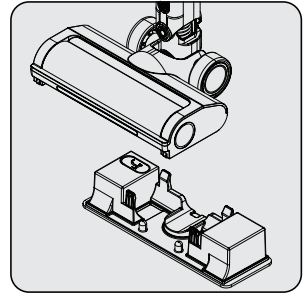

Attach mop attachment to the bottom of electrical turbo brush.



WARNING: Do not use the mop attachment on a carpet.



WARNING: Do not add bleach or excessively foaming liquid detergent into the water tank of mop attachment.



WARNING: Remove the mop attachment after usage is completed.



WARNING: Remove the mop attachment immediately after the mopping operation is completed to prevent damage to your wooden floors.



WARNING: After the mopping process is completed, empty the water remaining in the mop apparatus water tank and dry the tank.



Mopping cloths can be washed in washing machine.



WARNING: Do not lift or tilt the nozzle, as water may spray out of the water tank.



WARNING: The mop attachment is attached to the product. While mopping, do not mop or absorb water, coffee or tea deposits. These debris may get into the product and damage your device.

4 Operation

4.4 LED screen indicators

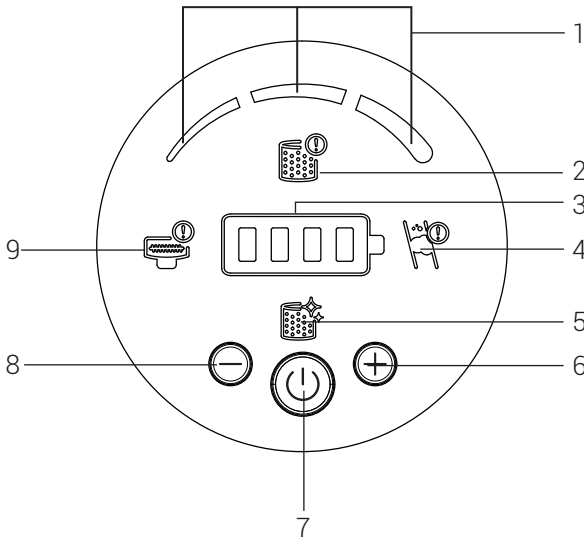

1. Those icons will show the suction mode which is being used.
2. If the prefilter or EPA12 is missing, this icon will warn you and the product will not turn on to prevent any damage to the Vacuum cleaner. Make sure the filters are correctly installed. Make sure the filters are installed.
3. Remain battery level status with iconic show
4. Indicates that there is air blockage. Please check the tube inside, the suction mouth of product body to find the foreign material that blocks the machine.
5. Indicates that the filter needs to be cleaned.
6. Speed boost button
7. On/Off button
8. Speed power reduction
9. Indicates that there is a blockage on the rollers and needs to be cleaned.

5 Cleaning and maintenance

Turn off and unplug the appliance before cleaning.



WARNING: Never use gasoline, solvent, abrasive cleaners, metal objects or hard brushes to clean the appliance.



WARNING: Deformation may occur on the filters within time as a result of usage. It shall be replaced with a new one to prevent loss of performance. Contact with the customer services to buy a new one.

5.1 Cleaning the Dust container and Filters



WARNING: Do not wash the filters.



We recommend you to clean the dust container after each operation.

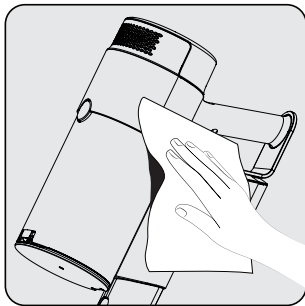

Wipe the surface of the body with a wet cloth.

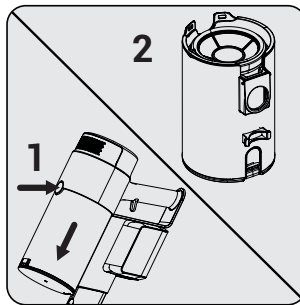

Press the dustbin release button and pull dustbin part.

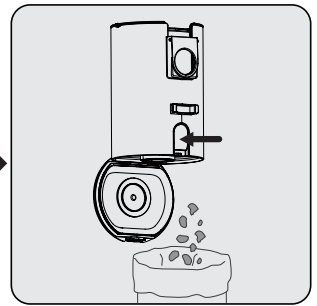

Press the dustbin cover release button and empty the dustbin.

5 Cleaning and maintenance

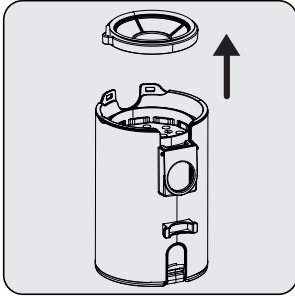

For a detailed cleaning of filters, remove the pre-filter part upward.

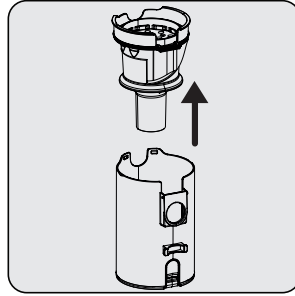

Pull the mesh filter part upward.

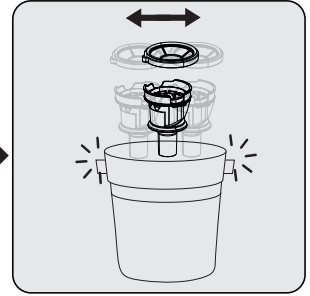

Clean the mesh filter and pre-filter by shaking in order to clean the dust.

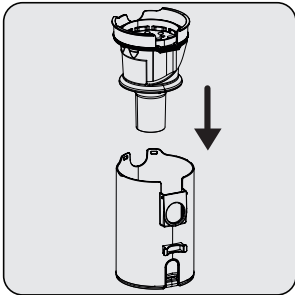

Insert the mesh filter into dustbin.

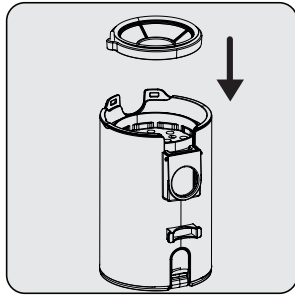

Insert the pre-filter on mesh filter.

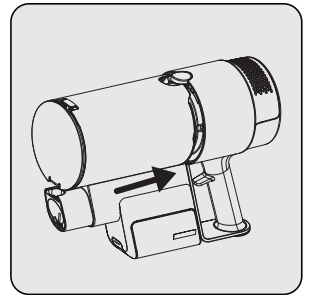

First, place the dustbin into its place horizontally, and then push the dustbin from bottom to be locked.

5 Cleaning and maintenance

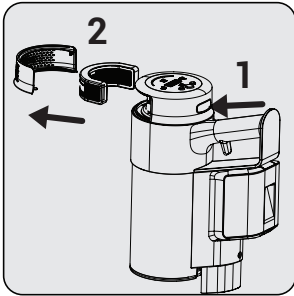

In order to clean EPA E12 Filter, press the button (1) and remove the filter part.

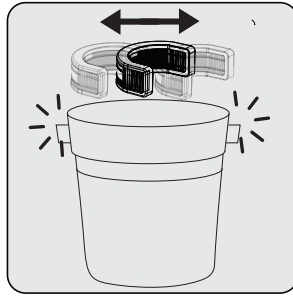

Clean the EPA E12 filter by shaking in order to clean the dust.

5.2 Cleaning of the brush



WARNING: Do not wash the turbo brush and the main roller.

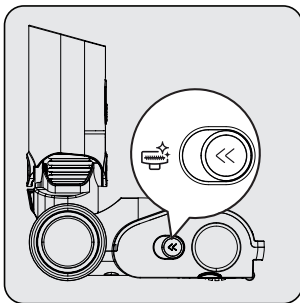

Push the roller release button to the left side.

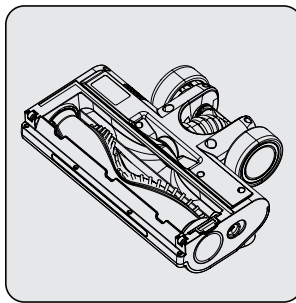

Remove the dust on it by tapping it lightly to a hard surface or remove the dust with a brush. If any hair, etc. is tangled, remove it by cutting it off.

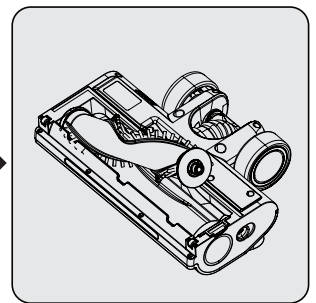

Fix the roller back to its place by pushing.

5 Cleaning and maintenance

5.3 Storage

- If you do not intend to use the appliance for a long time, store it carefully.
- Unplug the appliance.
- Ensure that the appliance is kept out of reach of children.
- Store the battery on a non-conducting material, and do not allow the battery to contact metal directly. This shall damage the battery.
- If you shall not be using the product for a long period of time, please at least keep it at half charged condition. Do not charge or discharge completely. The product should be recharged at least once every three months.

5.4 Transport and shipping

- During transport and shipping, carry the appliance with its original packaging. The packaging of the appliance will protect the appliance against physical damage.
- Do not put heavy objects on the appliance or its packaging. Otherwise the appliance may be damaged.
- If the appliance is dropped, the appliance may not operate or permanent damage may occur.

Product Guarantee

12 months breakdown and repair guarantee

Guarantor: **Beko plc, 1 Greenhill Crescent, Watford, Hertfordshire. WD18 8UF**

The guarantee does not in any way diminish your statutory or legal rights.

Your **appliance** has the benefit of our manufacturer's guarantee which covers the product for 12 months from the date of original purchase.

This gives you reassurance that if within that time, your **appliance** is proven to be defective because of either workmanship or materials, we will at our discretion either repair or replace your **appliance**.

The **appliance** must be correctly installed, located and operated in accordance with the instructions contained in the user manual. The guarantor disclaims any liability for accidental or consequential damage.

The Guarantee is subject to the following conditions:

- Documentary proof of the original purchase date is provided.
- The appliance has been installed and operated correctly and in accordance with our operating and maintenance instructions.
- The appliance is used only on the electricity supply on the rating plate.
- The appliance has only been used for normal domestic purposes.
- The appliance has not been altered, serviced, dismantled or otherwise interfered with by any person.
- The appliance is used in the United Kingdom or Republic of Ireland.
- Any parts removed during repair work or any product that has been replaced becomes our property.
- The guarantee is not transferrable if the product is resold.

The Guarantee does not cover:

- Transit, installation or delivery damage.
- Accidental damage.
- Misuse or abuse.
- Replacement of any consumable item or accessories. These include but are not limited to: plugs, cables, light bulbs, knobs, filters and flaps.
- Repairs or replacements required as a result of unauthorised repairs or inexpert installation that fails to meet the requirements contained in the user guide or instruction book.
- Repairs to products used in commercial or non-residential household premises.

How to obtain after sales service, help or general advice

Please keep your purchase receipt or other proof of purchase in a safe place as you will need to show us this document if your product requires attention within the guarantee period.

Please also record your product details below, which will allow you to access our services more quickly and help us identify your product. The model number is printed on the front of the user guide and the serial and model number is shown on your products rating plate.

Model number	Serial number	Purchased from	Date of purchase

Please call our UK based Customer Service department if you need help or advice from us:

United Kingdom and Northern Ireland: **0333 207 9710**

Republic of Ireland: **01 862 3411**

You can also contact us through our website: **www.beko.co.uk**

Arçelik A.Ş. Karaağaç Caddesi No:2-6, 34445,
Sütlüce, İSTANBUL, TÜRKİYE

www.beko.co.uk